

# Household Electronics

Diodes & Rectification  
Component Identification

# Diodes

- Diodes are essentially one-way current gates
- Symbolized by: 
- Current vs. voltage graphs:

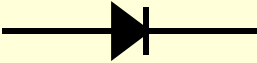
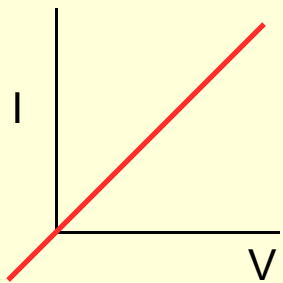
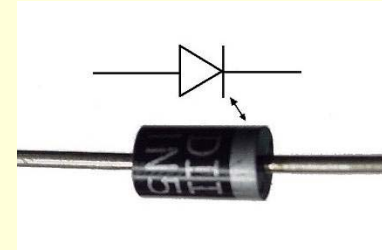

plain resistor

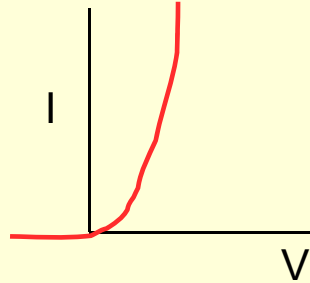

diode

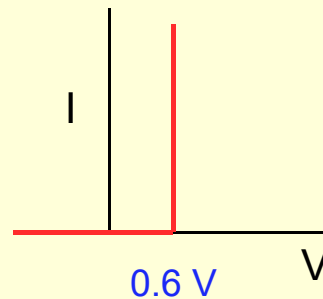

idealized diode

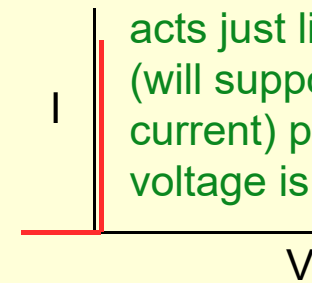

acts just like a wire  
(will support arbitrary  
current) provided that  
voltage is positive

WAY idealized diode

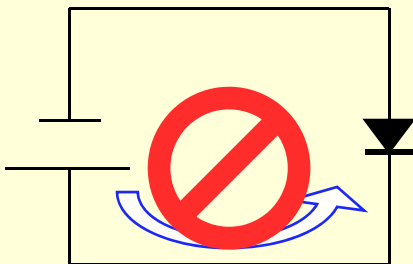

no current flows

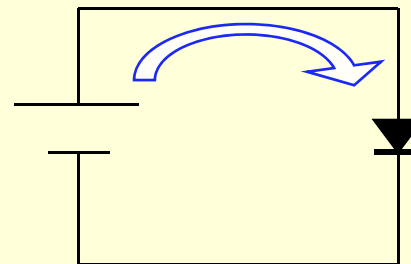

current flows

the direction the  
arrow points in the  
diode symbol is the  
direction that current  
*will* flow

# Diode Makeup

- Diodes are made of semiconductors (usually silicon)
- Essentially a stack of  $p$ -doped and  $n$ -doped silicon to form a  *$p$ - $n$  junction*
  - doping means deliberate impurities that contribute extra electrons ( $n$ -doped) or “holes” for electrons ( $p$ -doped)
- Transistors are  $n$ - $p$ - $n$  or  $p$ - $n$ - $p$  arrangements of semiconductors (like oreo cookies)

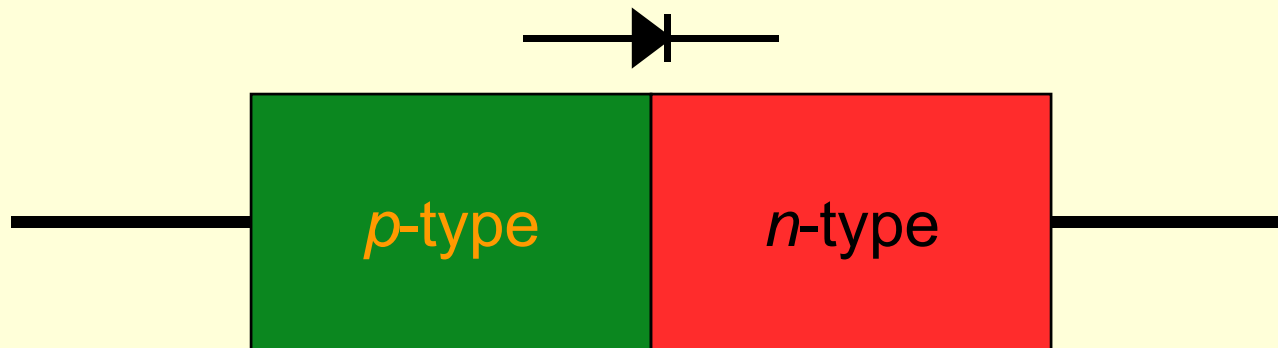

# LEDs: Light-Emitting Diodes

- Main difference is material is more exotic than silicon used in ordinary diodes/transistors
  - typically 2-volt drop instead of 0.6 V drop
- When electron flows through LED, loses energy by emitting a **photon** of light rather than vibrating lattice (heat)
- Anything with an LED cares about the battery orientation (it's still a diode, after all)
- LED efficiency is 30% (compare to incandescent bulb at 10%)

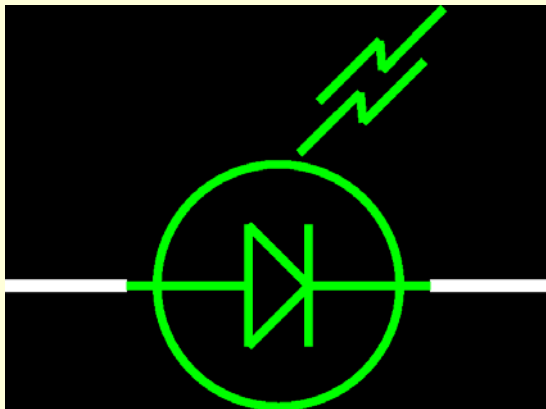

# Getting DC back out of AC

- AC provides a means for us to distribute electrical power, but most devices actually *want* DC
  - bulbs, toasters, heaters, fans don't care: plug straight in
  - sophisticated devices care because they have **diodes** and **transistors** that require a certain **polarity**
    - rather than oscillating polarity derived from AC
    - this is why battery orientation matters in most electronics
- Use diodes to “rectify” AC signal
- Simplest rectifier uses one diode:

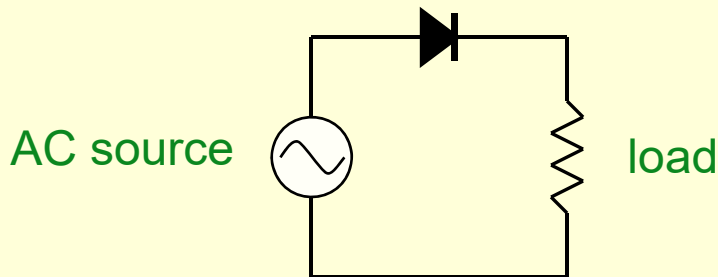

diode only conducts  
when input voltage is positive

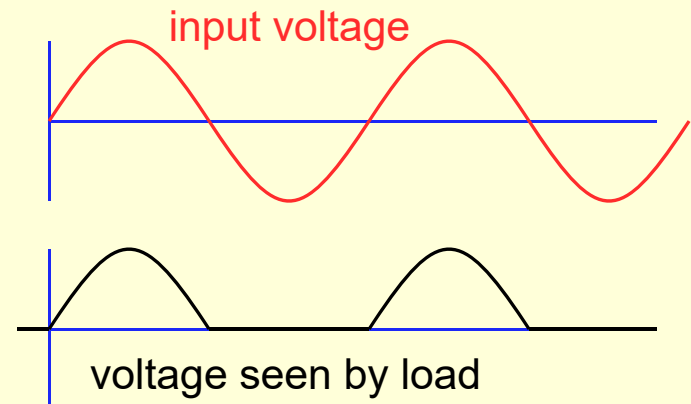

# Doing Better: Full-wave Diode Bridge

- The diode in the rectifying circuit simply prevented the negative swing of voltage from conducting
  - but this wastes half the available cycle
  - also very irregular (bumpy): far from a “good” DC source
- By using four diodes, you can recover the negative swing:

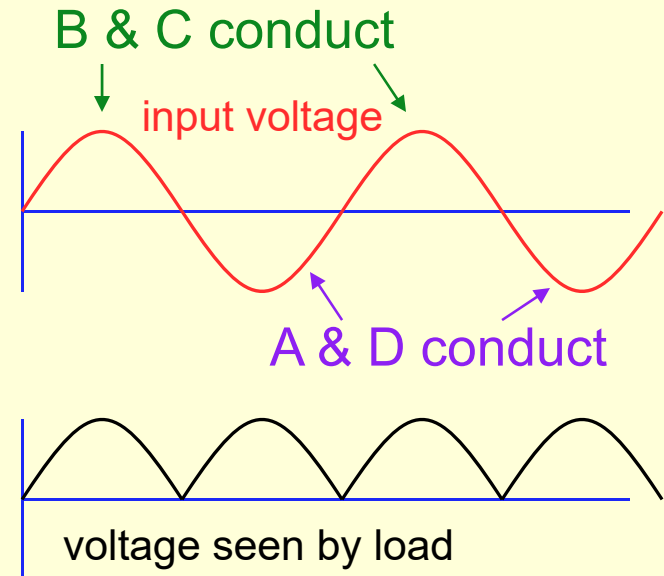
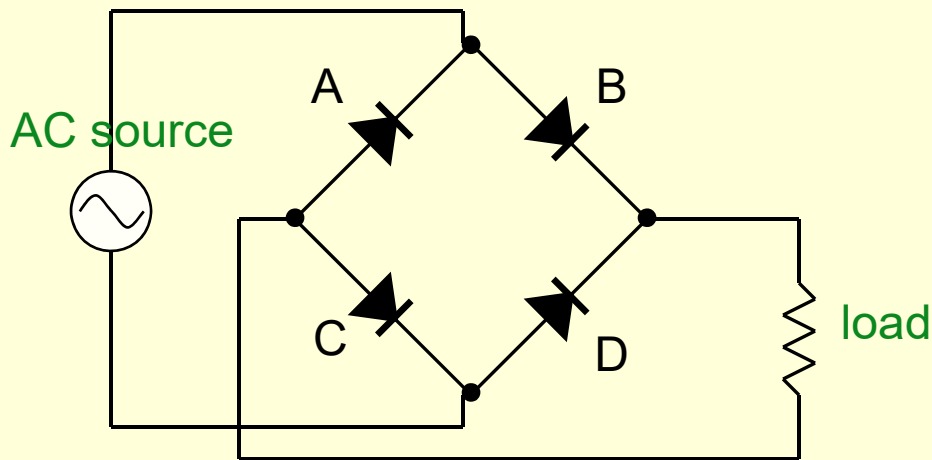

# Smoothing out the Bumps

- Still a bumpy ride, but we can smooth this out with a **capacitor**
  - capacitors have capacity for storing charge
  - acts like a reservoir to supply current during low spots
  - voltage regulator smoothes out remaining ripple

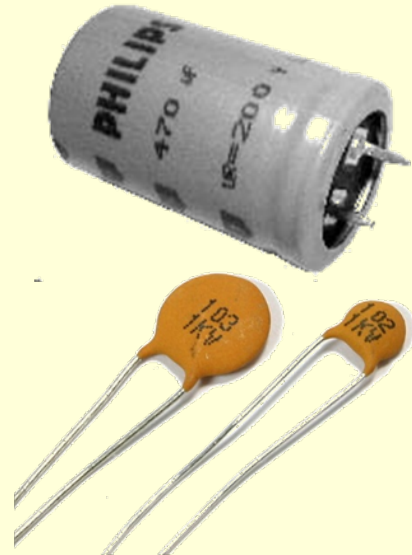
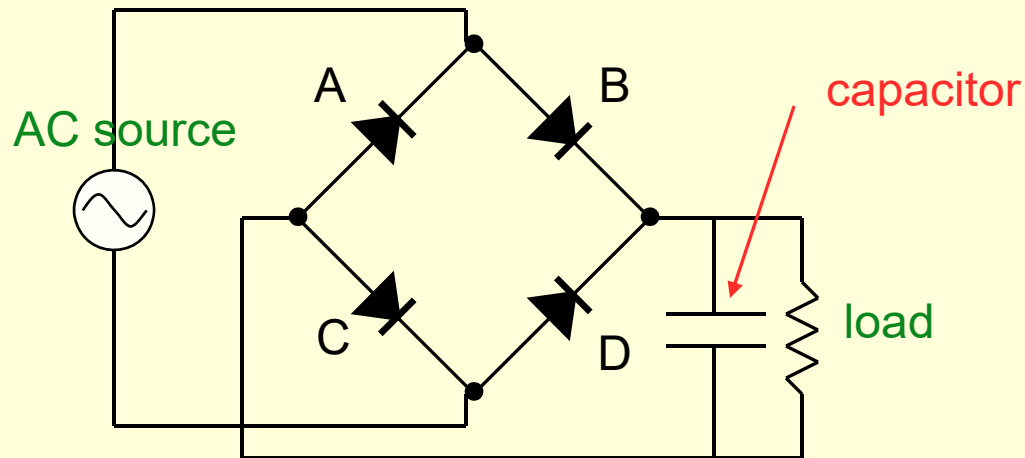
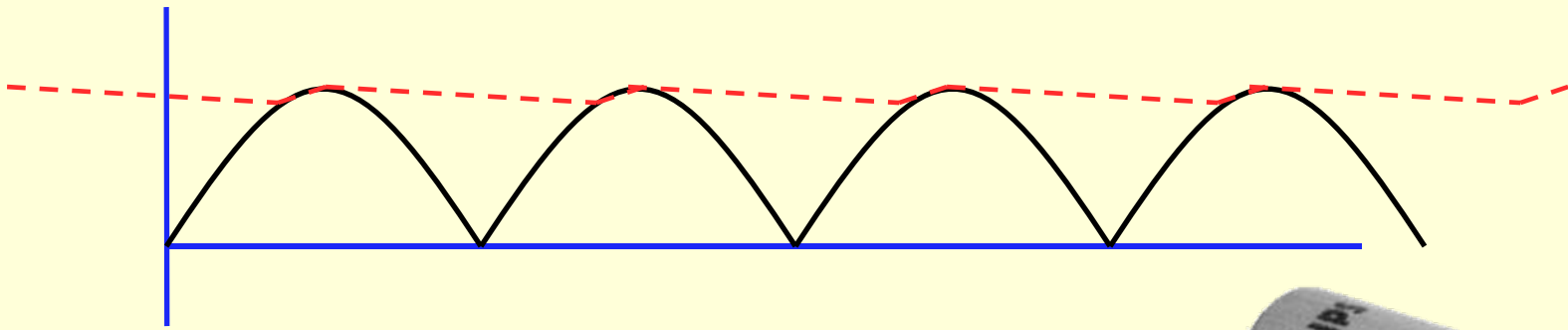

# Voltage Regulator: Setting the Voltage

- Can trim down ripple voltage to precise, rock-steady value
- Now things get complicated!
  - We are now in the realm of integrated circuits (ICs)
- ICs are whole circuits in small packages
- ICs contain resistors, capacitors, diodes, transistors, etc.

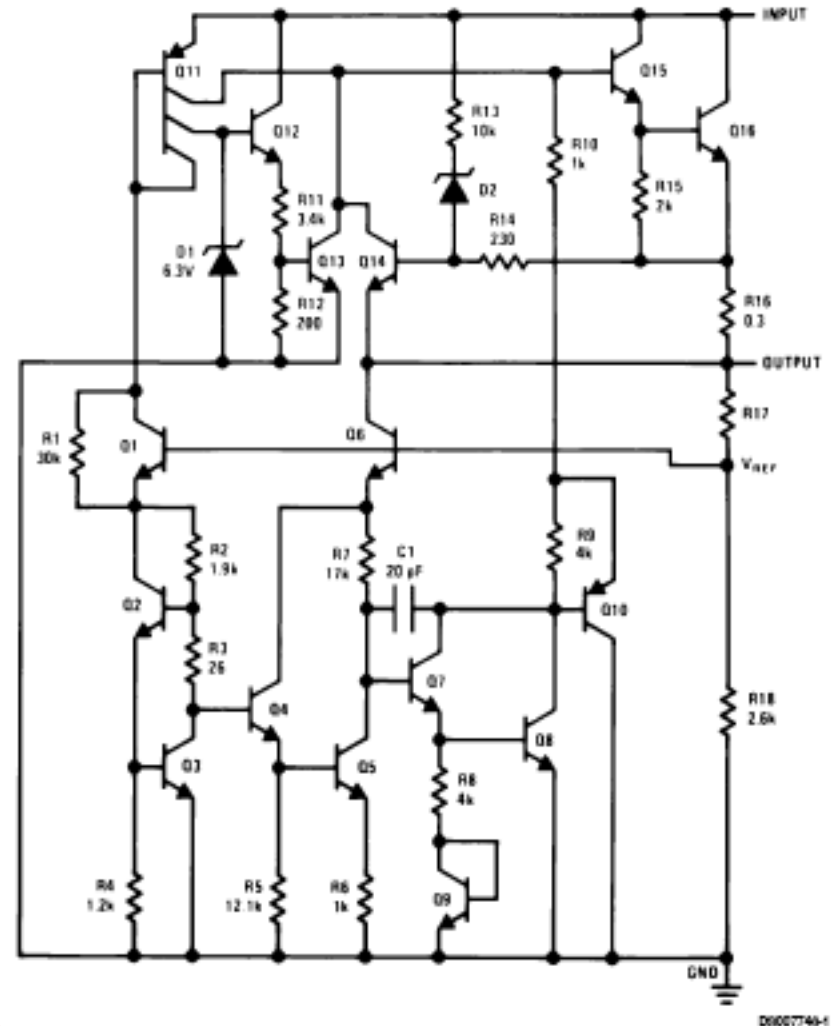
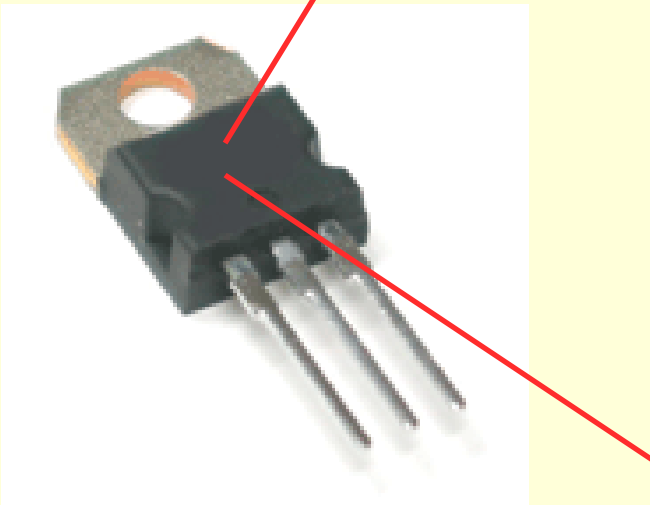

# Transistors: a brief glimpse

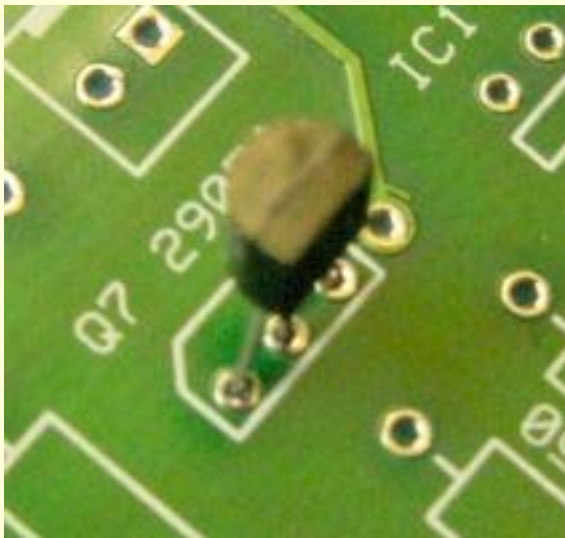
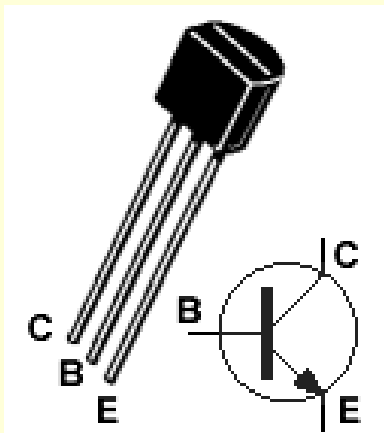

- Transistors have made our modern world possible
- Sort-of like diodes end-to-end (*npn* and *pnp* junctions)
  - but the sandwiched junction is very thin, and this is important
- A small current on the “base” can control a large current flowing from “collector” to “emitter”
- Can be used as an **amplifier**
  - make a weak signal stronger
- Or used as a **switch**
  - pedal-to-the-metal saturation regime
- Both are *incredibly* useful

# Operational Amplifiers (Op-amps)

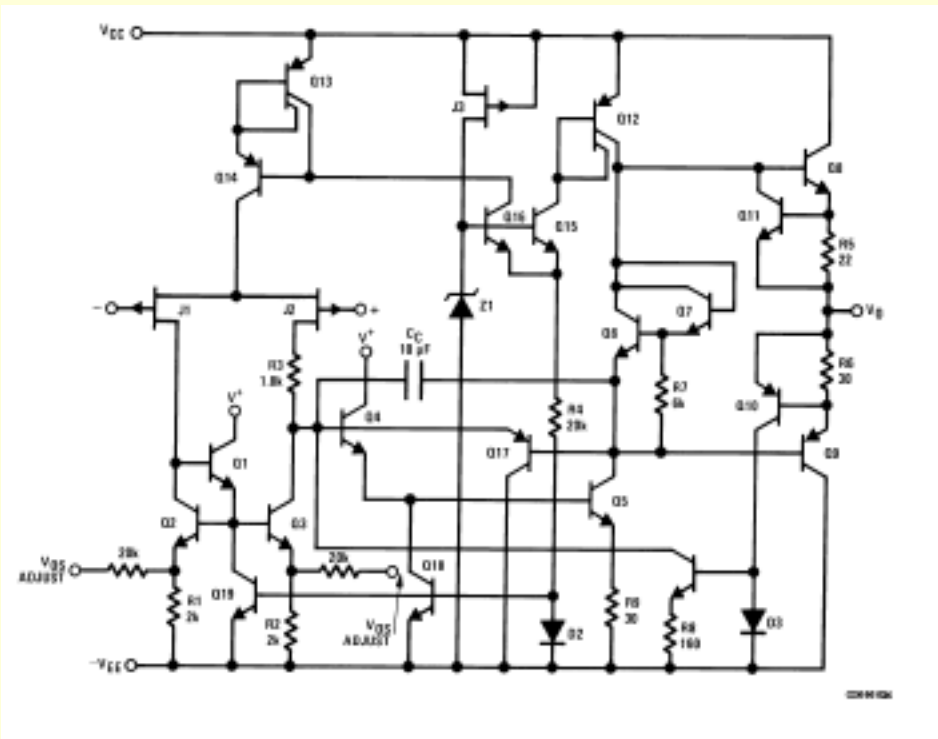

- In essence, an op-amp is an idealized transistor/amplifier
- Has > 20 transistors inside
- Idyllic properties:
  - linear amplification
  - temperature insensitivity
  - versatile
- So useful that electronics builders have trays full of them, and use them like “jelly-beans”

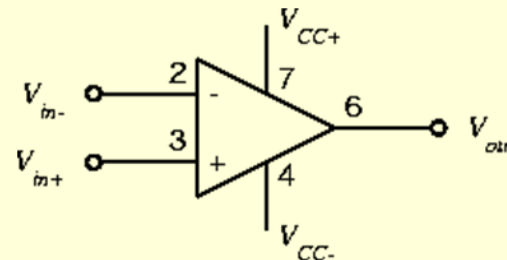

# Assignments/Announcements

- Q/O #2 due tomorrow by 6 PM
- **Midterm 5/04 (next Thu.) 2PM WLH 2005**
  - will post study guide on course website
  - will have review session TBA
  - Use Green Scantron: Form No.: X-101864
  - Bring #2 pencil, calculators okay