

# Semiconductors, diodes, transistors

- Electrical conductivity
  - Energy bands in solids
  - Band structure and conductivity
- Semiconductors
  - Intrinsic semiconductors
  - Doped semiconductors
    - ◆ n-type materials
    - ◆ p-type materials
- Diodes and transistors
  - p-n junction
  - depletion region
  - forward biased p-n junction
  - reverse biased p-n junction
  - diode
  - bipolar transistor
  - operation of bipolar pnp transistor
  - FET

# ELECTRICAL CONDUCTIVITY

- in order of conductivity: superconductors, conductors, semiconductors, insulators
  - conductors: material capable of carrying electric current, i.e. material which has "mobile charge carriers" (e.g. electrons, ions,...)  
e.g. metals, liquids with ions (water, molten ionic compounds), plasma
  - insulators: materials with no or very few free charge carriers; e.g. quartz, most covalent and ionic solids, plastics
  - semiconductors: materials with conductivity between that of conductors and insulators; e.g. germanium *Ge*, silicon *Si*, *GaAs*, *GaP*, *InP*
  - superconductors: certain materials have zero resistivity at very low temperature.
- some representative resistivities ( $\rho$ ):
  - $R = \rho L/A$ ,  $R$  = resistance,  $L$  = length,  $A$  = cross section area; resistivity at 20° C

	resistivity in $\Omega \text{ m}$	resistance(in $\Omega$ )( $L=1\text{m}$ , diam =1mm)
◆ aluminum	$2.8 \times 10^{-8}$	$3.6 \times 10^{-2}$
◆ brass	$\approx 8 \times 10^{-8}$	$10.1 \times 10^{-2}$
◆ copper	$1.7 \times 10^{-8}$	$2.2 \times 10^{-2}$
◆ platinum	$10 \times 10^{-8}$	$12.7 \times 10^{-2}$
◆ silver	$1.6 \times 10^{-8}$	$2.1 \times 10^{-2}$
◆ carbon	$3.5 \times 10^{-5}$	44.5
◆ germanium	0.45	$5.7 \times 10^5$
◆ silicon	$\approx 640$	$\approx 6 \times 10^8$
◆ porcelain	$10^{10} - 10^{12}$	$10^{16} - 10^{18}$
◆ teflon	$10^{14}$	$10^{20}$
◆ blood	1.5	$1.9 \times 10^6$
◆ fat	24	$3 \times 10^7$

# ENERGY BANDS IN SOLIDS:

- In solid materials, electron energy levels form bands of allowed energies, separated by forbidden bands
- valence band = outermost (highest) band filled with electrons ("filled" = all states occupied)
- conduction band = next highest band to valence band (empty or partly filled)
- "gap" = energy difference between valence and conduction bands, = width of the forbidden band
- Note:
  - ◆ electrons in a completely filled band cannot move, since all states occupied (Pauli principle); only way to move would be to "jump" into next higher band - needs energy;
  - ◆ electrons in partly filled band can move, since there are free states to move to.
- Classification of solids into three types, according to their band structure:
  - ◆ insulators: gap = forbidden region between highest filled band (valence band) and lowest empty or partly filled band (conduction band) is very wide, about 3 to 6 eV;
  - ◆ semiconductors: gap is small - about 0.1 to 1 eV;
  - ◆ conductors: valence band only partially filled, or (if it is filled), the next allowed empty band overlaps with it

# Band structure and conductivity

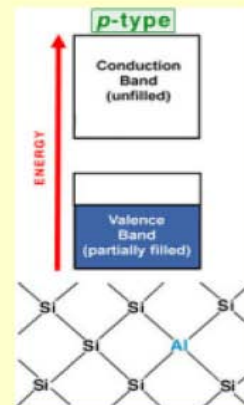
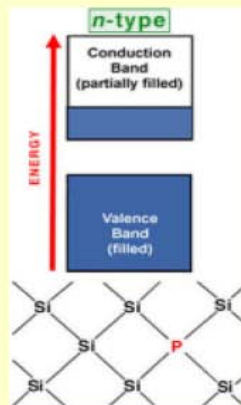
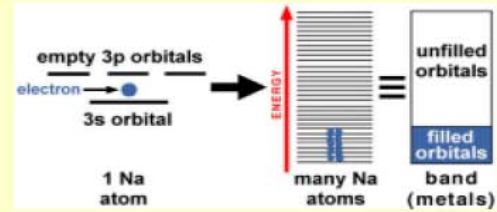
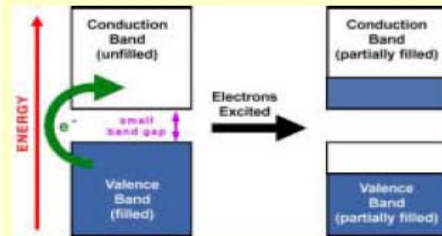
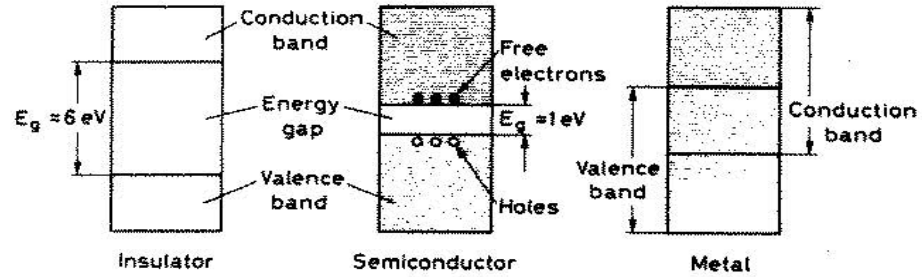

# INTRINSIC SEMICONDUCTORS

- semiconductor = material for which gap between valence band and conduction band is small; (gap width in Si is 1.1 eV, in Ge 0.7 eV).
- at  $T = 0$ , there are no electrons in the conduction band, and the semiconductor does not conduct (lack of free charge carriers);
- at  $T > 0$ , some fraction of electrons have sufficient thermal kinetic energy to overcome the gap and jump to the conduction band;  
fraction rises with temperature;  
e.g. at  $20^\circ\text{C}$  (293 K), Si has  $0.9 \times 10^{10}$  conduction electrons per cubic centimeter; at  $50^\circ\text{C}$  (323 K) there are  $7.4 \times 10^{10}$ .
- electrons moving to conduction band leave "hole" (covalent bond with missing electron) behind;  
under influence of applied electric field, neighboring electrons can jump into the hole, thus creating a new hole, etc.  $\Rightarrow$  holes can move under the influence of an applied electric field, just like electrons;  
both contribute to conduction.
- in pure Si and Ge, there are equally many holes ("p-type charge carriers") as there are conduction electrons ("n-type charge carriers");
- pure semiconductors also called "intrinsic semiconductors".

- **Intrinsic silicon:**

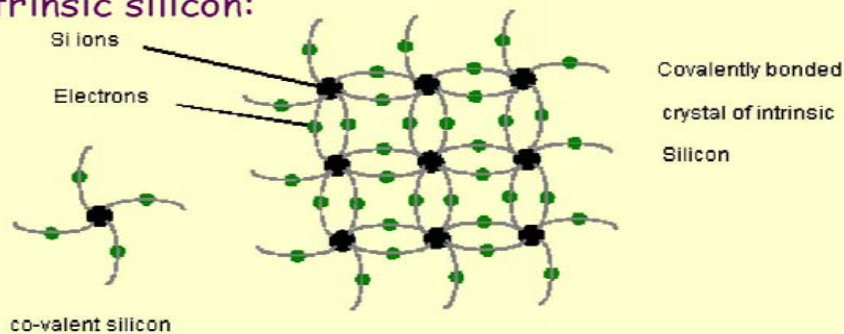

- **DOPED SEMICONDUCTORS:**

- "doped semiconductor": (also "impure", "extrinsic") = semiconductor with small admixture of trivalent or pentavalent atoms;

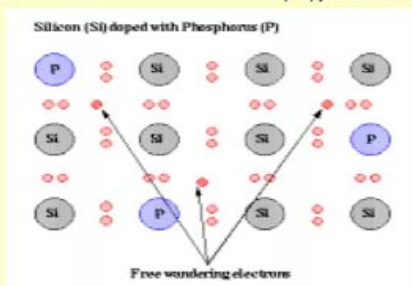
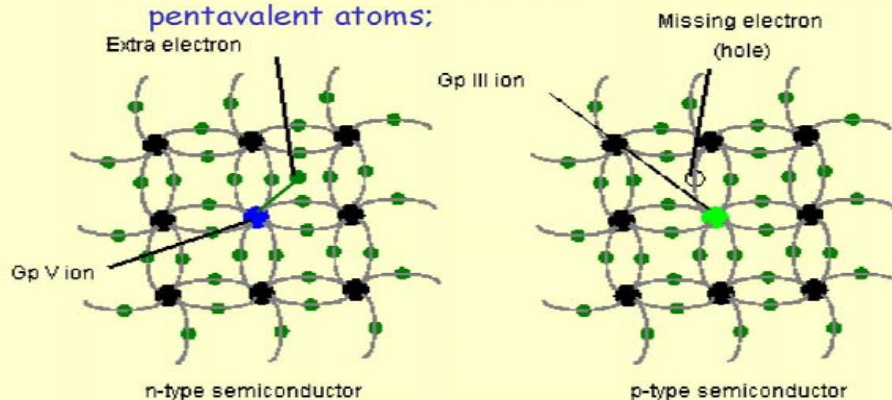

## n-type material

- **donor (n-type) impurities:**
  - ◆ dopant with 5 valence electrons (e.g. P, As, Sb)
  - ◆ 4 electrons used for covalent bonds with surrounding Si atoms, one electron "left over";
  - ◆ left over electron is only loosely bound  $\Rightarrow$  only small amount of energy needed to lift it into conduction band (0.05 eV in Si)
  - ◆  $\Rightarrow$  "**n-type semiconductor**", has conduction electrons, no holes (apart from the few intrinsic holes)
  - ◆ example: doping fraction of  $10^{-8}$  Sb in Si yields about  $5 \times 10^{16}$  conduction electrons per cubic centimeter at room temperature, i.e. gain of  $5 \times 10^6$  over intrinsic Si.

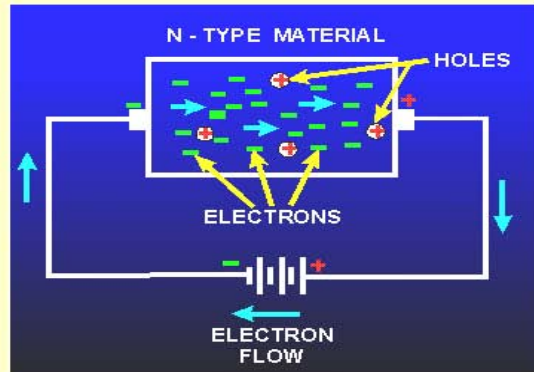

## p-type material

- **acceptor (p-type) impurities:**
  - ◆ dopant with 3 valence electrons (e.g. B, Al, Ga, In)  $\Rightarrow$  only 3 of the 4 covalent bonds filled  $\Rightarrow$  vacancy in the fourth covalent bond  $\Rightarrow$  hole
  - ◆ "**p-type semiconductor**", has mobile holes, very few mobile electrons (only the intrinsic ones).
- advantages of doped semiconductors:
  - ◆ can "tune" conductivity by choice of doping fraction
  - ◆ can choose "majority carrier" (electron or hole)
  - ◆ can vary doping fraction and/or majority carrier within piece of semiconductor
  - ◆ can make "p-n junctions" (diodes) and "transistors"

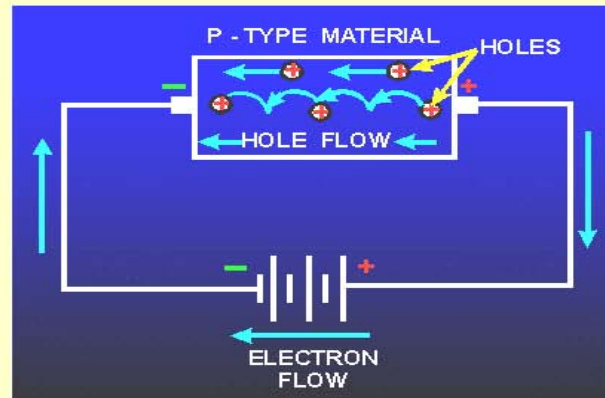

# DIODES AND TRANSISTORS

## ■ p-n JUNCTION:

- ◆ p-n junction = semiconductor in which impurity changes abruptly from p-type to n-type ;
- ◆ "diffusion" = movement due to difference in concentration, from higher to lower concentration;
- ◆ in absence of electric field across the junction, holes "diffuse" towards and across boundary into n-type and capture electrons;
- ◆ electrons diffuse across boundary, fall into holes ("*recombination of majority carriers*");
  - ⇒ formation of a "depletion region"  
(= region without free charge carriers)  
around the boundary;
- ◆ charged ions are left behind (cannot move):
  - negative ions left on p-side ⇒ net negative charge on p-side of the junction;
  - positive ions left on n-side ⇒ net positive charge on n-side of the junction
  - ⇒ electric field across junction which prevents further diffusion.

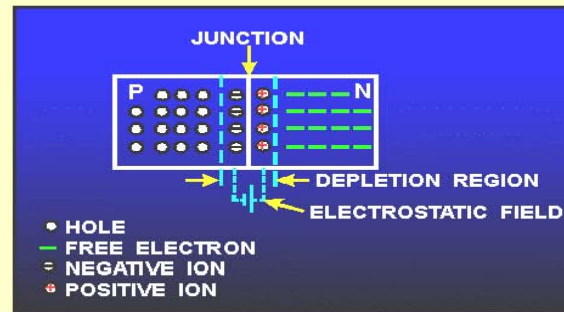

## Pn junction

- Formation of depletion region in pn-junction:

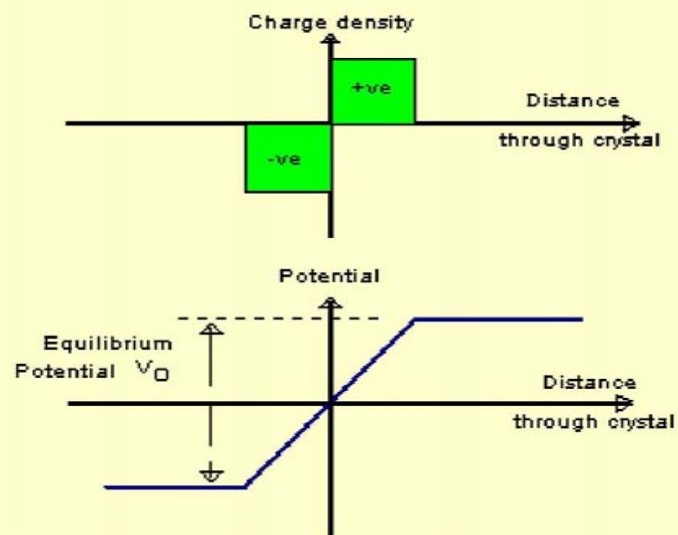
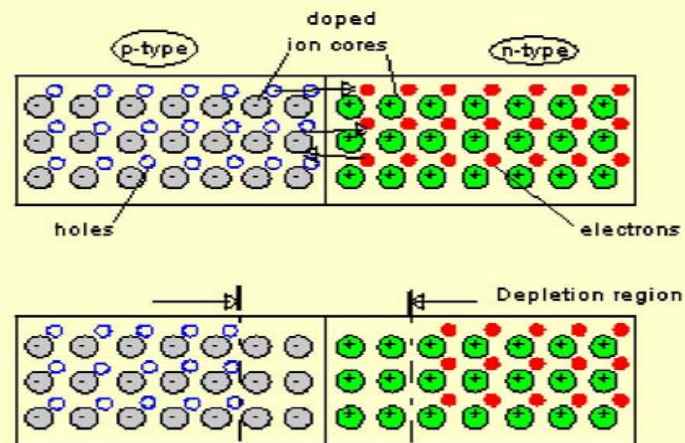

# DIODE

- diode = "biased p-n junction", i.e. p-n junction with voltage applied across it
- "forward biased": p-side more positive than n-side;
- "reverse biased": n-side more positive than p-side;
- forward biased diode:
  - ◆ the direction of the electric field is from p-side towards n-side
  - ◆  $\Rightarrow$  p-type charge carriers (positive holes) in p-side are pushed towards and across the p-n boundary,
  - ◆ n-type carriers (negative electrons) in n-side are pushed towards and across n-p boundary

$\Rightarrow$  current flows across p-n boundary

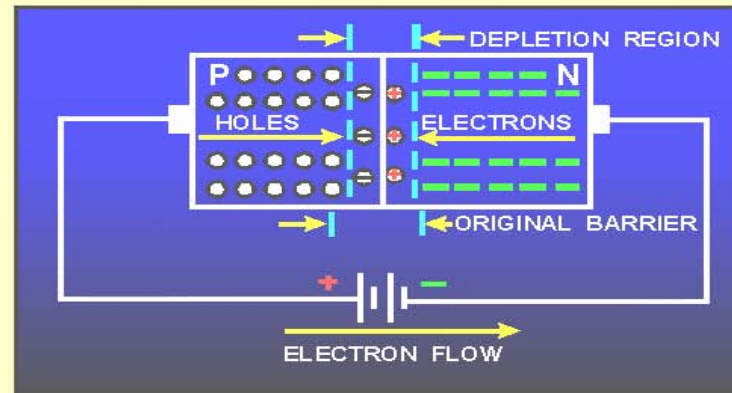

## Forward biased pn-junction

- Depletion region and potential barrier reduced

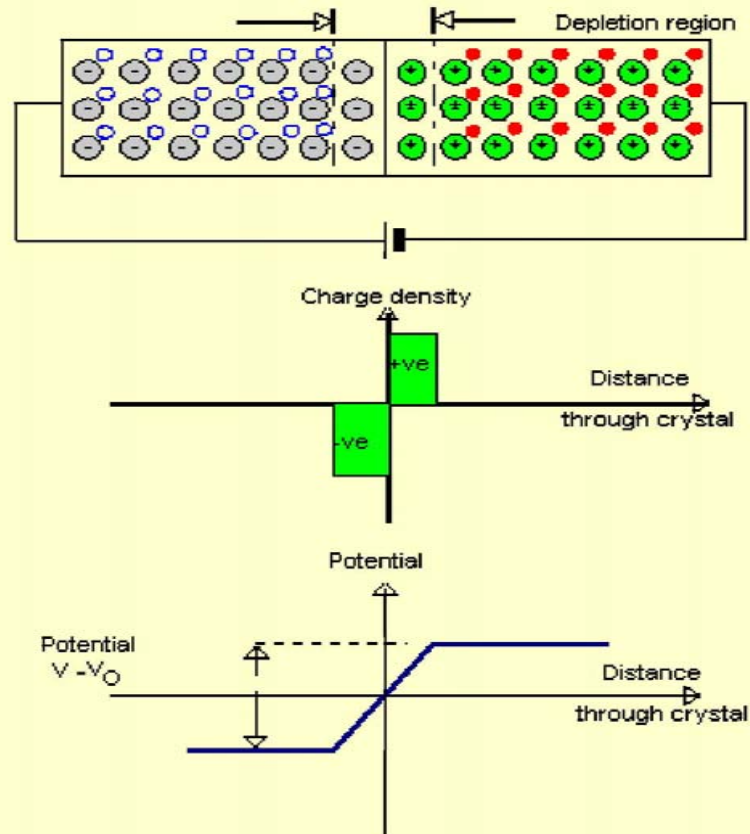

## Reverse biased diode

- reverse biased diode: applied voltage makes n-side more positive than p-side
  - ⇒ electric field direction is from n-side towards p-side
  - ⇒ pushes charge carriers away from the p-n boundary
  - ⇒ depletion region widens, and no current flows

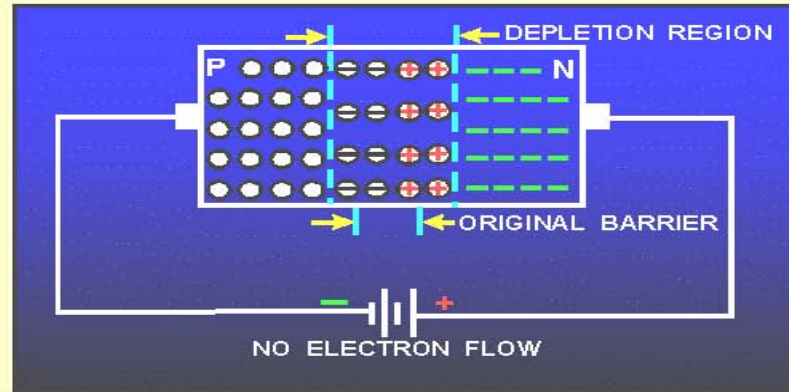

- diode only conducts when positive voltage applied to p-side and negative voltage to n-side
- diodes used in "rectifiers", to convert ac voltage to dc.

## Reverse biased diode

- Depletion region becomes wider, barrier potential higher

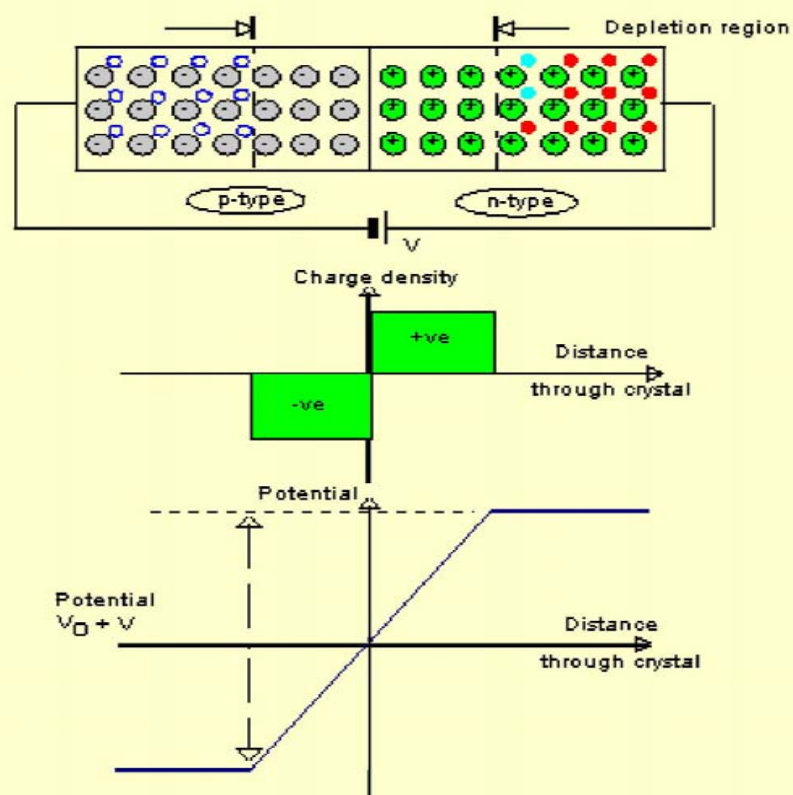

# TRANSISTORS

- (bipolar) transistor = combination of two diodes that share middle portion, called "base" of transistor; other two sections: "emitter" and "collector";
- usually, base is very thin and lightly doped.
- two kinds of bipolar transistors: pnp and npn transistors
- "pnp" means emitter is p-type, base is n-type, and collector is p-type material;
- in "normal operation of pnp transistor, apply positive voltage to emitter, negative voltage to collector;

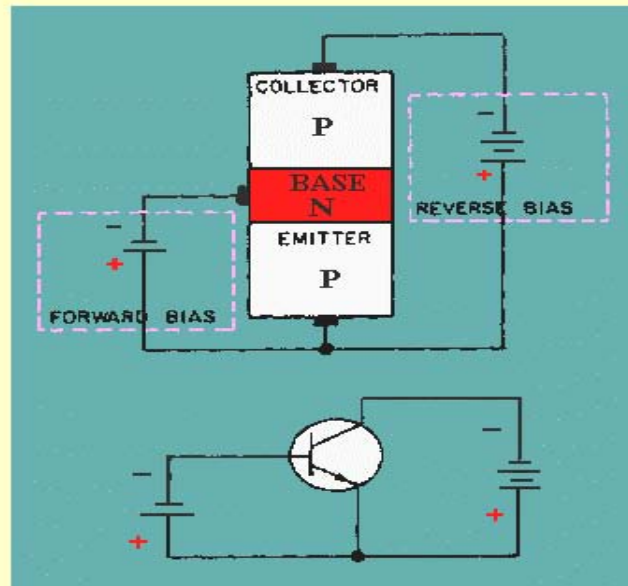

## operation of pnp transistor:

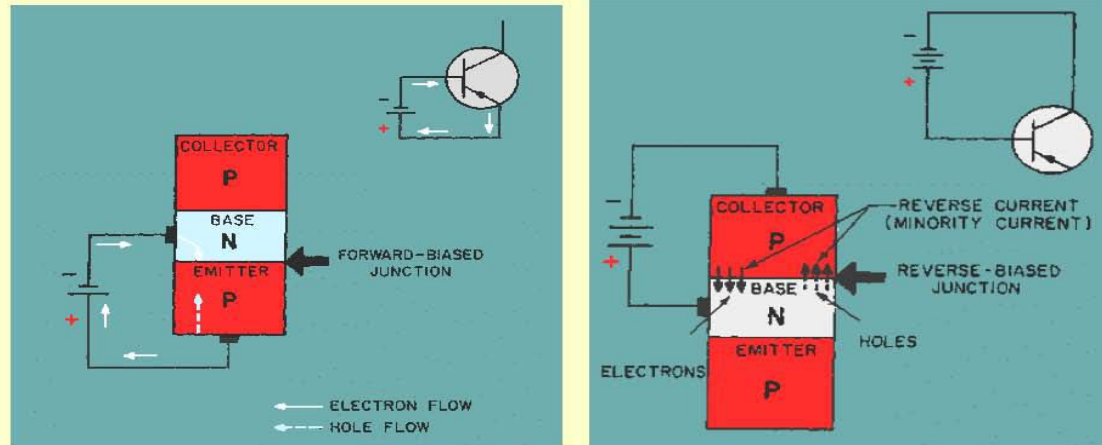

- if emitter-base junction is forward biased, "holes flow" from battery into emitter, move into base;
- some holes annihilate with electrons in n-type base, but base thin and lightly doped  $\Rightarrow$  most holes make it through base into collector,
- holes move through collector into negative terminal of battery; i.e. "collector current" flows whose size depends on how many holes have been captured by electrons in the base;
- this depends on the number of n-type carriers in the base which can be controlled by the size of the current (the "base current") that is allowed to flow from the base to the emitter; the base current is usually very small; small changes in the base current can cause a big difference in the collector current;

## Transistor operation

- transistor acts as amplifier of base current, since *small changes in base current cause big changes in collector current.*
- **transistor as switch:** if voltage applied to base is such that emitter-base junction is reverse-biased, no current flows through transistor -- transistor is "off"
- therefore, a transistor can be used as a voltage-controlled switch; computers use transistors in this way.

- "field-effect transistor" (FET)

- in a pnp FET, current flowing through a thin channel of n-type material is controlled by the voltage (electric field) applied to two pieces of p-type material on either side of the channel (current depends on electric field).

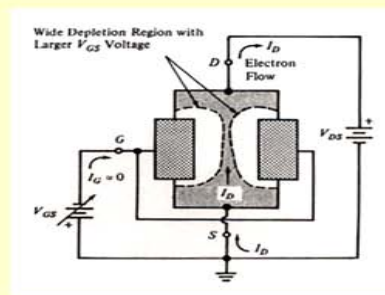
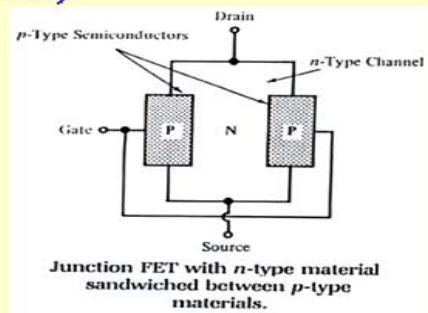

- Many different kinds of FETs
- FETs are the kind of transistor most commonly used in computers.